



文星電子股份有限公司

WENSHING ELECTRONICS CO., LTD.

11054 台北市信義區崇德街 82 號
TEL: +886-2-27353055 (代表號)

No.82, Chong De St, 11054 Shin Yi District, Taipei, Taiwan
FAX: +886-2-27328813

Electrical Features

Specification	
Size	50mm*50mm
Center Frequency	922±3 MHz
Bandwidth	8MHz min. @S11≤-10 dB
Standing Wave	≤1.5
Antenna Gain	4 dBic (50mm*50mm When grounded)
Axis Ratio	3.0 dB Typ.
Working Temperature	-40°C to +85°C
Limit Temperature	-40°C to +85°C
Relative Humidity	10 to 95% RH



文星電子股份有限公司

WENSHING ELECTRONICS CO., LTD.

11054 台北市信義區崇德街 82 號
TEL: +886-2-27353055 (代表號)

No.82, Chong De St, 11054 Shin Yi District, Taipei, Taiwan
FAX: +886-2-27328813

Return Loss and Smith Chart for Ceramic Patch

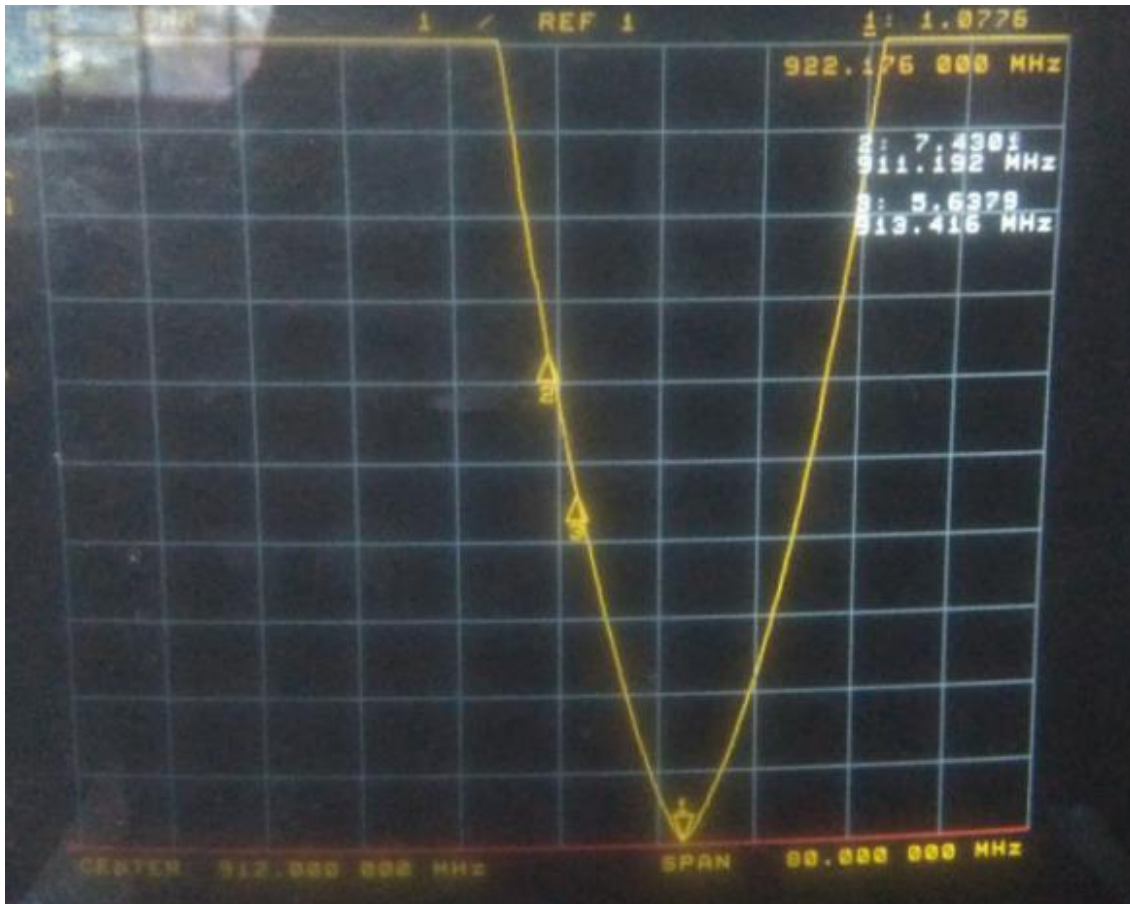

Structure and Material

NO.	Description	Structure and Material
1	Antenna Substrate	Dielectric Ceramics
2	Pin	Copper, Tin Plated
3	Electrode	Ag Plated
4	Ground Base	Ag Plated
5	Adhesive Type	3M T : 0.13mm



文星電子股份有限公司

WENSHING ELECTRONICS CO., LTD.

11054 台北市信義區崇德街 82 號
TEL: +886-2-27353055 (代表號)

No.82, Chong De St, 11054 Shin Yi District, Taipei, Taiwan
FAX: +886-2-27328813

Specification Dimension Chart

L : 40.0 ± 0.3 mm

W : 40.0 ± 0.3 mm

H : 5.0 ± 0.1 mm

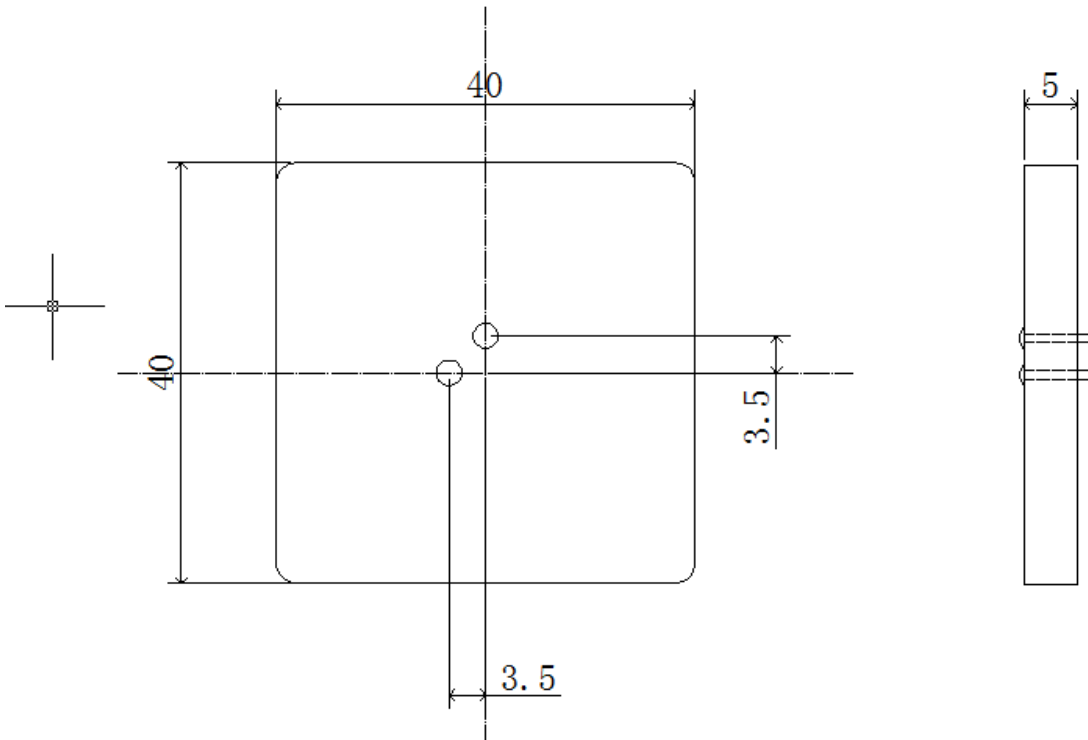

Recommended Soldering Condition

Manual Soldering

- Ironing Power : Max 30W
- Preheat : 150 °C / 60 sec.
- Solder Horn Temperature : Max 350°C.
- Soldering Time : Max 3 sec.
- Tin Solder : Sn/3.0Ag/0.5Cu
- Manual Soldering : Max 1 time

