

UHF RFID 機器人讀寫器

AT Command

Model : WS-RFIDBY



Version History

Version	Date	Changes
V1.01	17, April, 2017	1 st Edition
V1.02	21, August, 2018	2 st Edition

Installation Direction (安裝在牆壁上時)

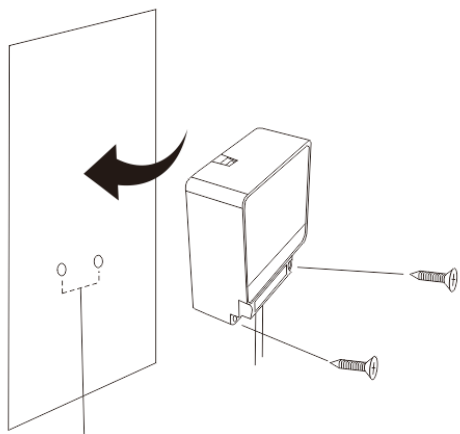

兩個螺絲孔之間的距離為 47.5mm

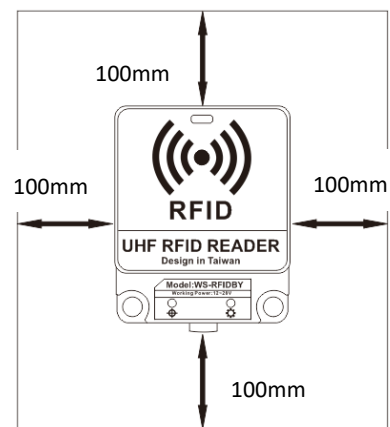

WS-RFIDBY 四周必需淨空至少 100mm，才不會影響天線的性能

WS-RFIDBY-TCP (網線插入、電源插入)

1. DC 12V 2A

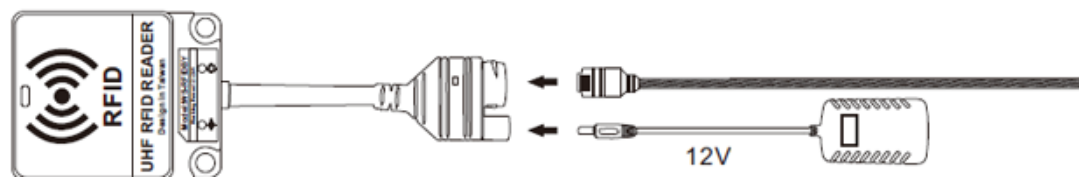

2. POE

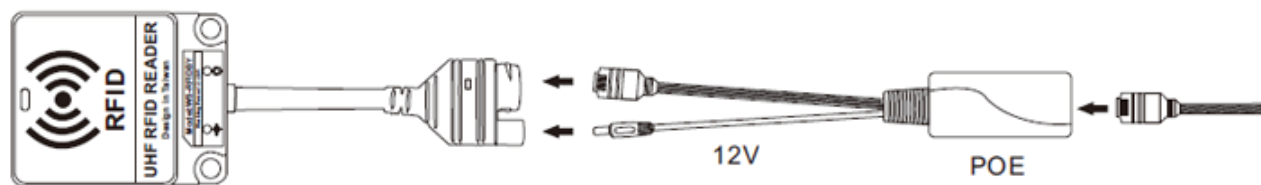

RS-232 及 RS-485 接線方式 (WS-RFIDBY-RS232 及 WS-RFIDBY-RS485)

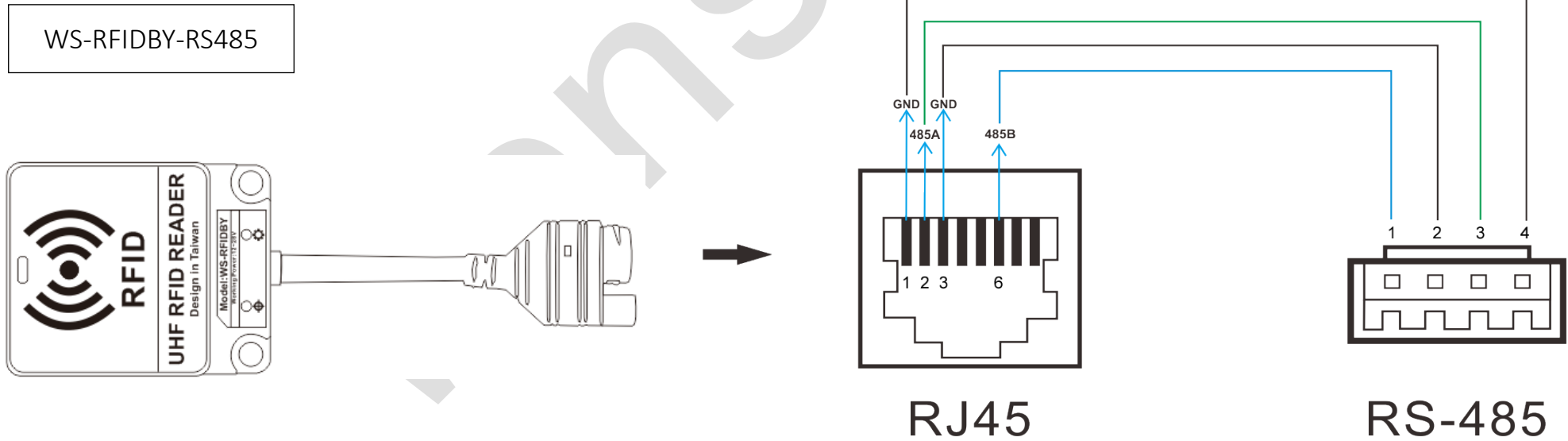
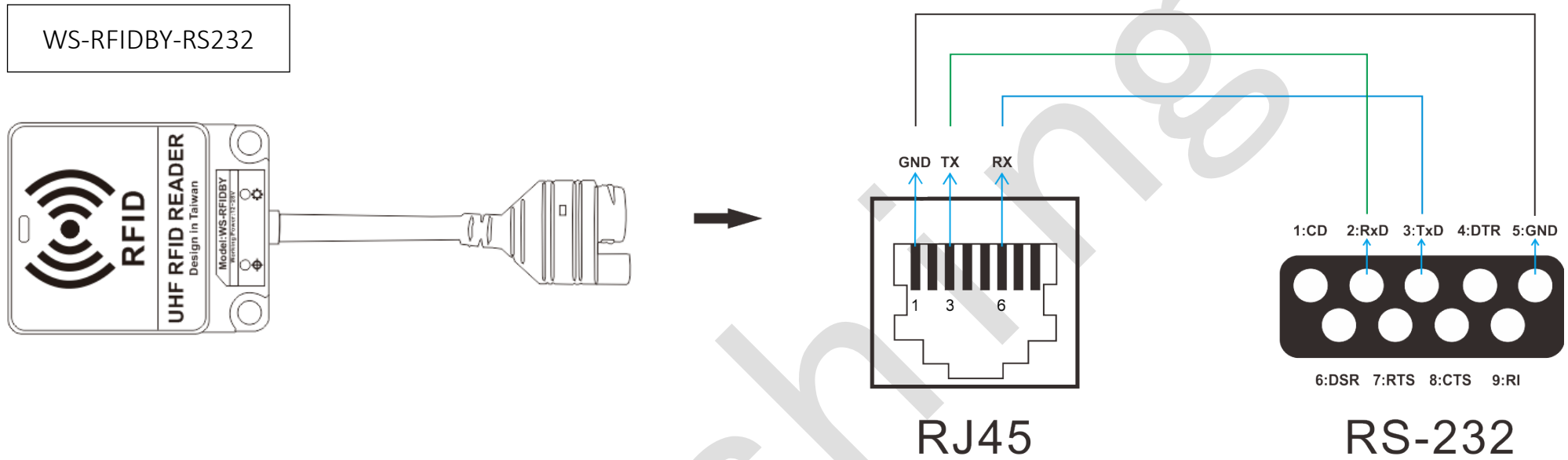

燈號指示說明

連接指示燈：有連接網路時燈號恆亮

狀態指示燈：待機狀態=綠燈恆亮

讀取 Tag=藍燈恆亮 2 秒

設備異常=紅燈恆亮

更新模式=綠燈閃爍

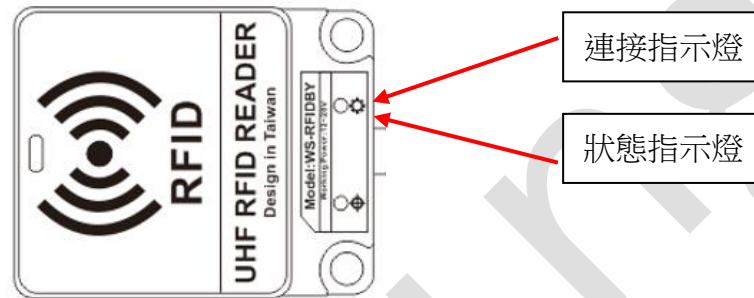

網路設定方式 (WS-RFIDBY-TCP Only)

1. 將 WS-RFIDBY-TCP 插入電源及網路線 (連接電腦或區域網路)。
2. 執行 “Wenshing All in one NET tools” ，開啟後畫面如下：

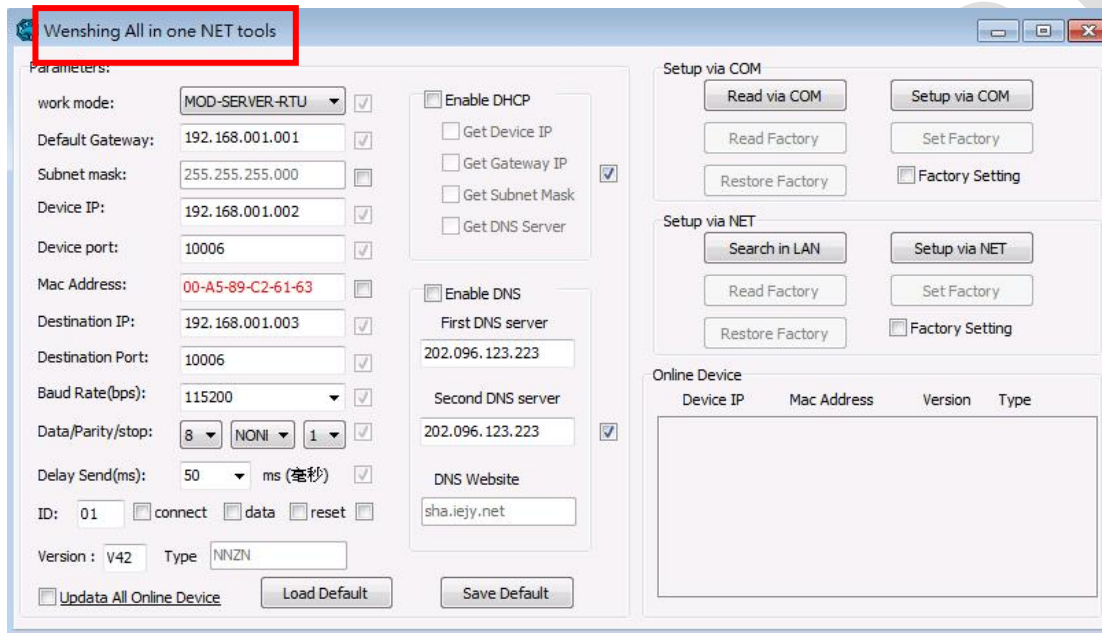

3. 搜尋區域網路內的設備，點選“Search in LAN” 按鍵：

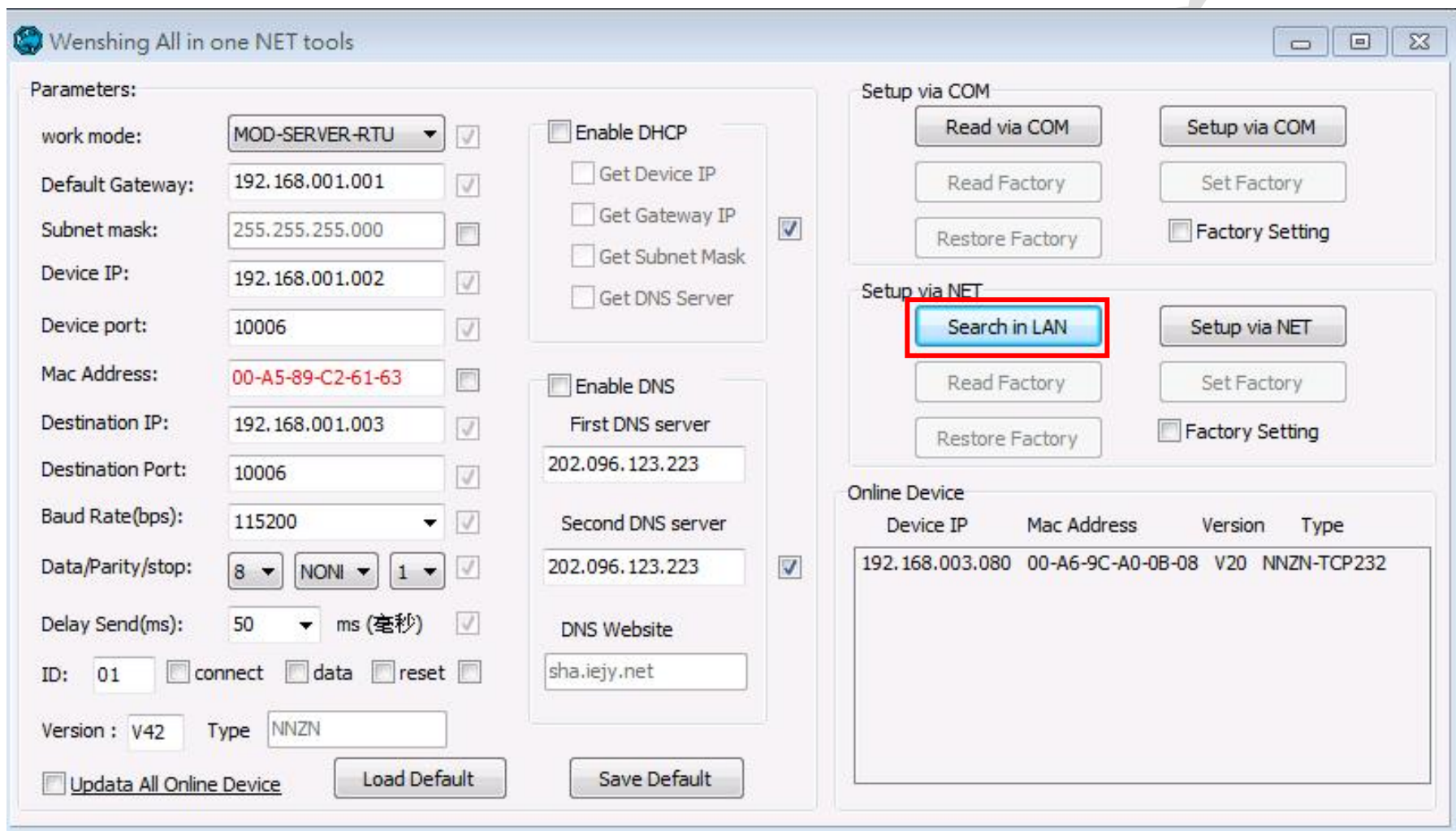

Wenshing All in one NET tools

Parameters:

work mode: MOD-SERVER-RTU

Default Gateway: 192.168.001.001

Subnet mask: 255.255.255.000

Device IP: 192.168.001.002

Device port: 10006

Mac Address: 00-A5-89-C2-61-63

Destination IP: 192.168.001.003

Destination Port: 10006

Baud Rate(bps): 115200

Data/Parity/stop: 8 NONI 1

Delay Send(ms): 50 ms (毫秒)

ID: 01 connect data reset

Version: V42 Type NNZN

Update All Online Device

Enable DHCP

Get Device IP

Get Gateway IP

Get Subnet Mask

Get DNS Server

Enable DNS

First DNS server

202.096.123.223

Second DNS server

202.096.123.223

DNS Website

sha.iejy.net

Setup via COM

Factory Setting

Setup via NET

Factory Setting

Online Device

Device IP	Mac Address	Version	Type
192.168.003.080	00-A6-9C-A0-0B-08	V20	NNZN-TCP232

4. 搜尋到設備後會在下面顯示出該設備的 IP 位置：

Online Device			
Device IP	Mac Address	Version	Type
192.168.003.080	00-A6-9C-A0-0B-08	V20	NNZN-TCP232

5. 讀取網路設定參數，點擊兩次搜尋到的設備 IP 後會自動讀取目前的設定並在左邊“Parameters”顯示：

The screenshot shows the 'Wenshing All in one NET tools' software interface. The 'Parameters' section on the left is highlighted with a red box, showing the following settings:

- work mode: TCP-CLIENT
- Default Gateway: 192.168.003.250
- Subnet mask: 255.255.255.000
- Device IP: 192.168.003.080
- Device port: 08080
- Mac Address: 00-A6-9C-A0-0B-08
- Destination IP: 192.168.003.100
- Destination Port: 08080
- Baud Rate(bps): 115200
- Data/Parity/stop: 8, NONI, 1
- Delay Send(ms): 50 ms (毫秒)
- ID: 1
- Version: V20, Type: NNZN-TCP232

The 'Online Device' table at the bottom right is also highlighted with a red box, showing the same device information as in the previous screenshot:

Device IP	Mac Address	Version	Type
192.168.003.080	00-A6-9C-A0-0B-08	V20	NNZN-TCP232

6. 修改網路設定參數，直接在左邊“Parameters”修改適合的設定，並按“Setup via NET”進行修改 (不可使用 Port 5978)：

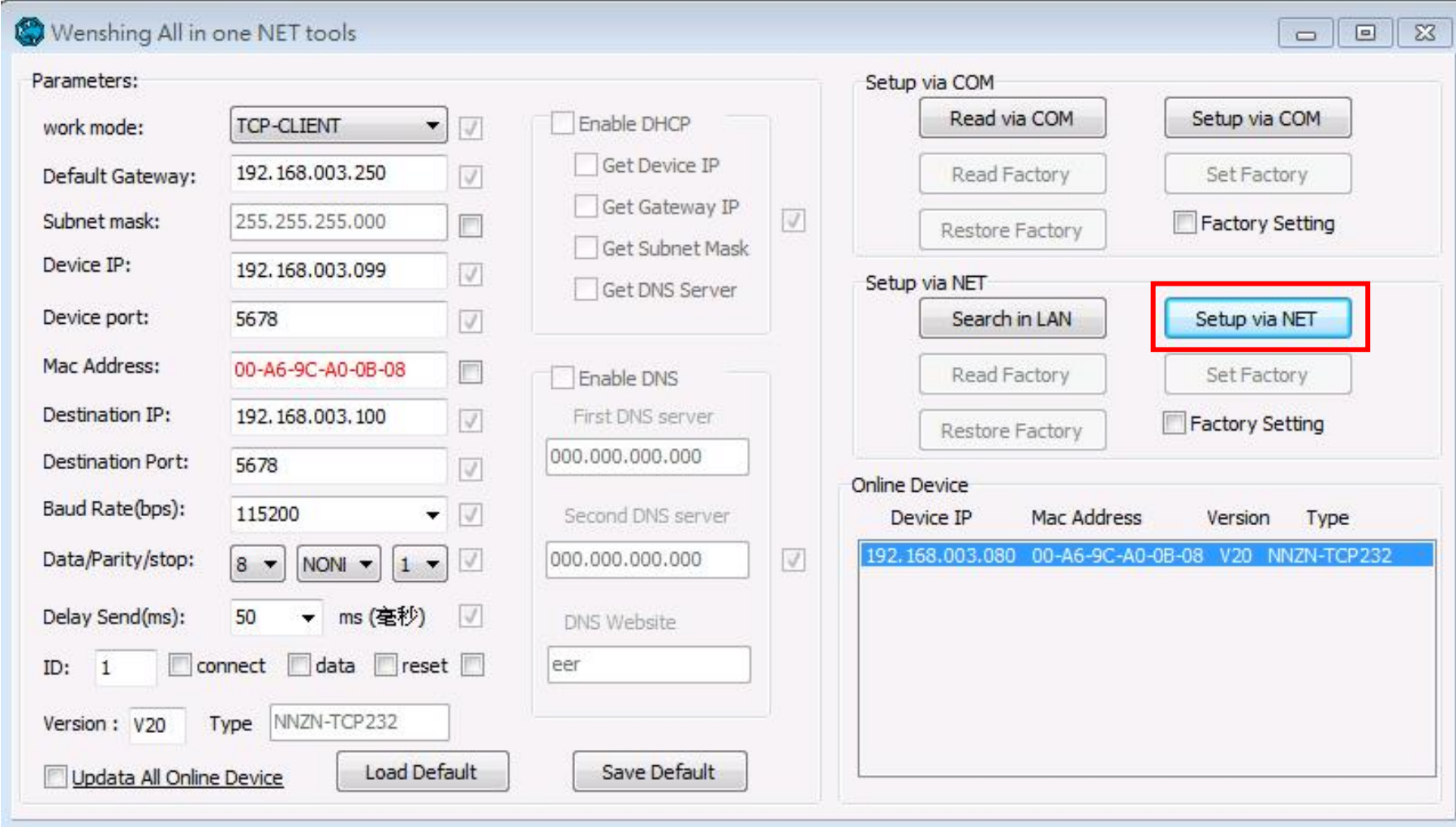

Wenshing All in one NET tools

Parameters:

work mode: TCP-CLIENT

Default Gateway: 192.168.003.250

Subnet mask: 255.255.255.000

Device IP: 192.168.003.099

Device port: 5678

Mac Address: 00-A6-9C-A0-0B-08

Destination IP: 192.168.003.100

Destination Port: 5678

Baud Rate(bps): 115200

Data/Parity/stop: 8 NONI 1

Delay Send(ms): 50 ms (毫秒)

ID: 1 connect data reset

Version: V20 Type: NNZN-TCP232

Update All Online Device

Setup via COM

Factory Setting

Setup via NET

Factory Setting

Online Device

Device IP	Mac Address	Version	Type
192.168.003.080	00-A6-9C-A0-0B-08	V20	NNZN-TCP232

7. 修改成功則會跳出下列提示：

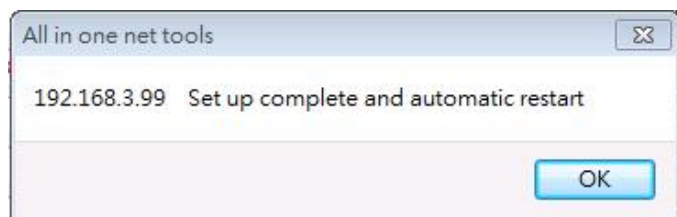

8. 重新啟動，將 WS-RFIDBY-TCP 設備拔除電源再重新插上，再次點選 “Search in LAN” 按鍵並點擊兩次搜尋到的設備 IP 以讀取網路設定參數，確認網路設定是否正確：

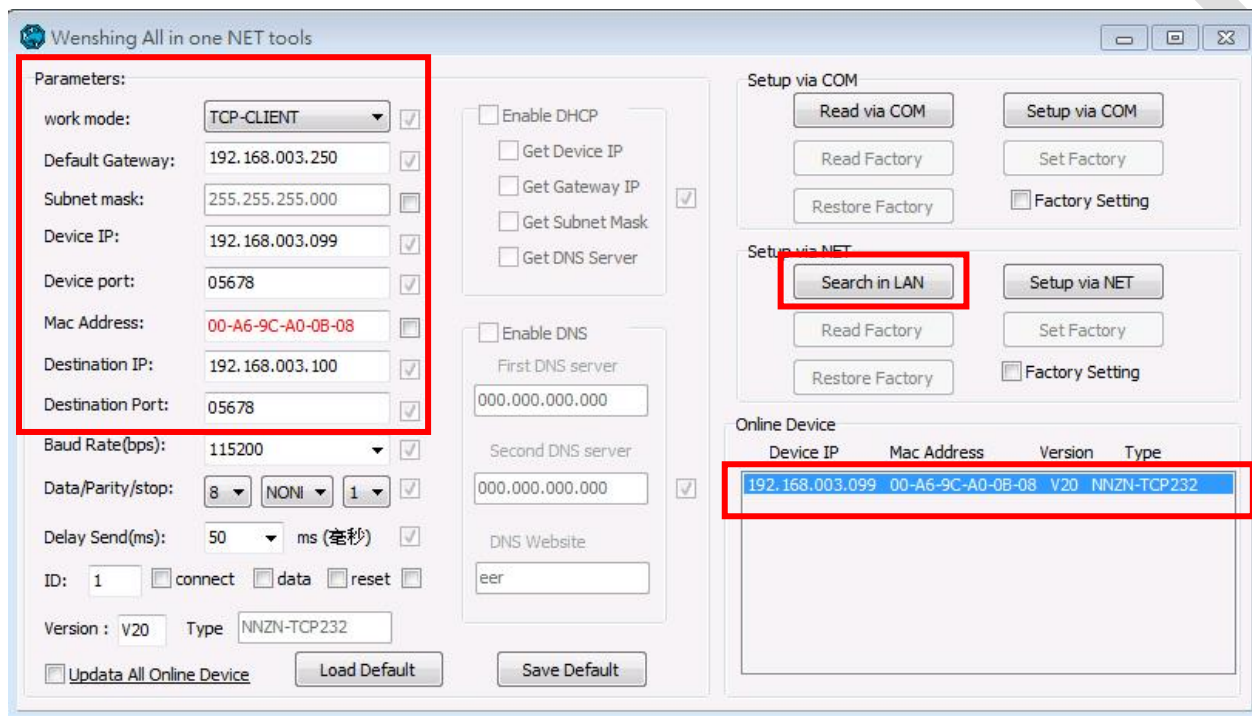

PC 有線網路設定方式 (WS-RFIDBY-TCP Only)

1. 設定 PC 網路參數，依照所設定的參數修改 PC 端對應的設定：

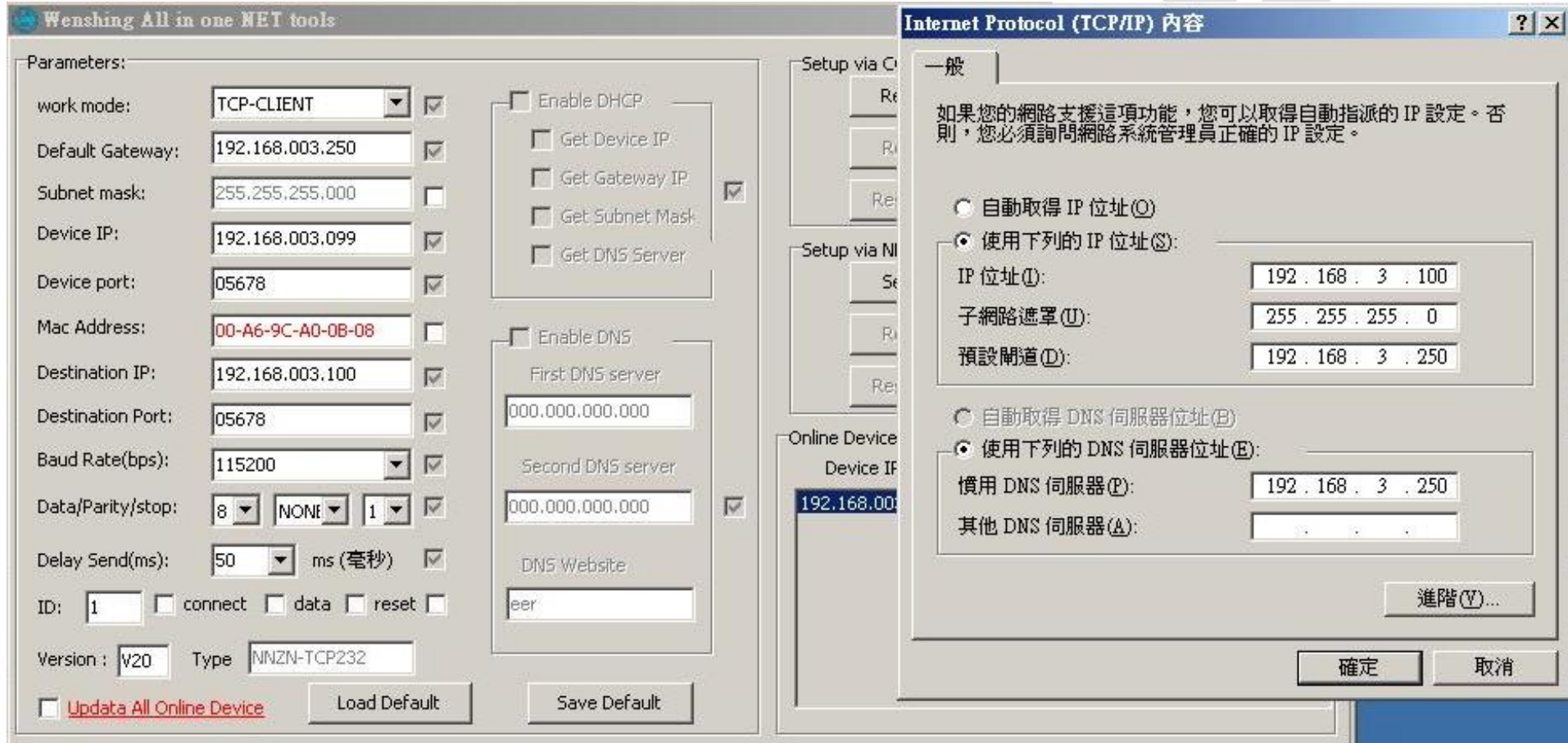

2. 測試通訊，PC 端執行“TCP Server”軟體並設定對應的 Port 號，發送 AT 指令測試通訊是否正確（不可使用 Port 5978）：

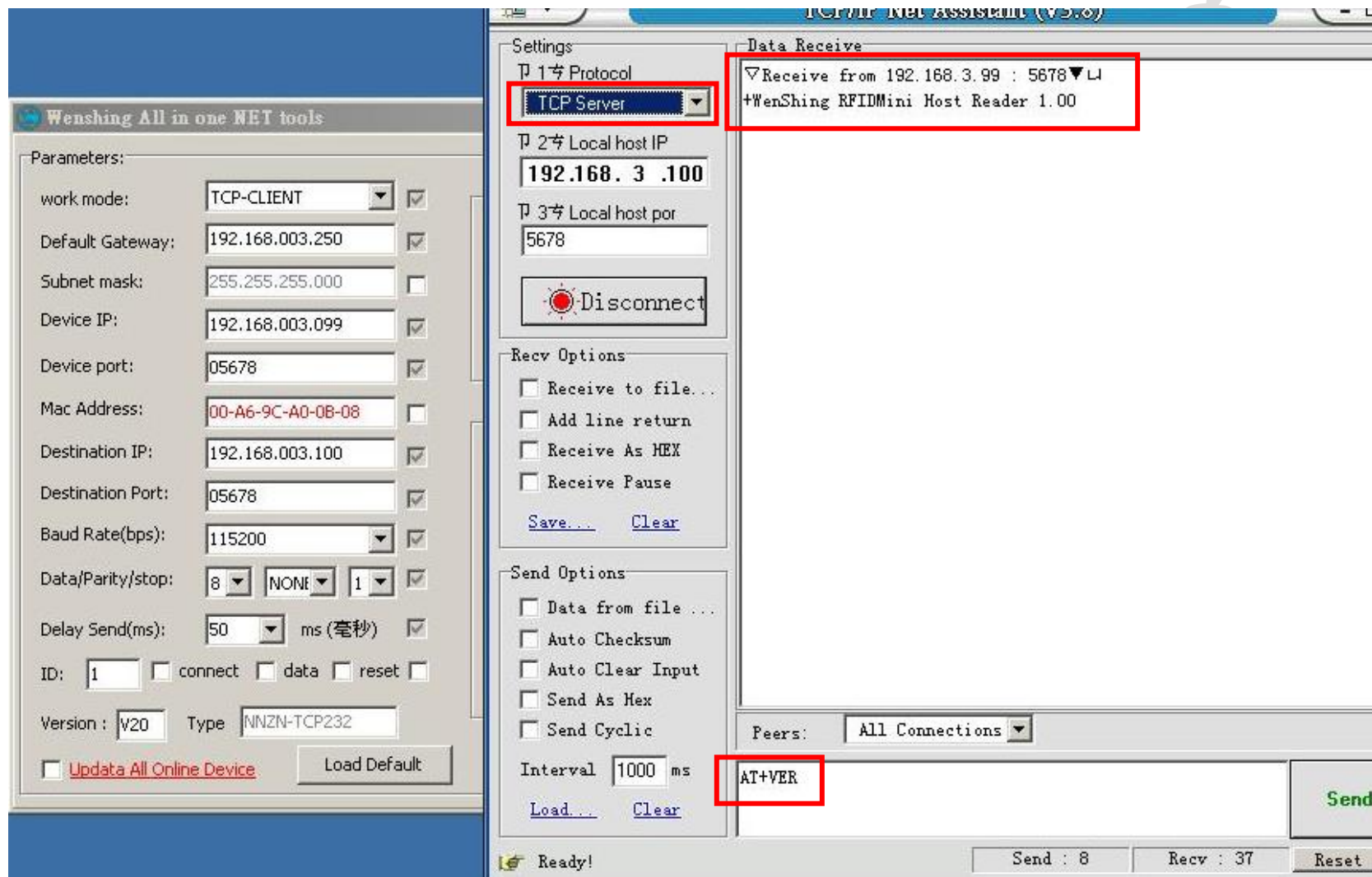

Output Data Format

Byte1 = 0x53 Suggesting output data is Tag TID ; Data format reference as below :

Byte 0	Byte 1	Byte 2	Byte 3~N	Byte N+1
0x02	0x53	Length of data being read	Tag TID	0x03

Byte1 =0x54 Suggesting output data is Tag EPC ; Data format reference as below :

Byte 0	Byte 1	Byte 2	Byte 3	Byte 4~6	Byte 7	Byte 8~9	Byte 10~N	Byte N+1
0x02	0x54	Length of data being read	RSSI value being received	Frequency being received and Antenna port	PC+EPC Length	PC (Tag assortment)	Tag EPC	0x03

Byte 4 is frequency low byte

Byte 5 is frequency middle byte

Byte 6 is frequency high byte and antenna port

When bit 7=1 the frequency value is 0E, bit 7=0 the frequency value is 0D

Bit 0~5 is received antenna port , antenna 1=0 0000 、 antenna 2=0 0001 、 antenna 3=0 0010 、 antenna 4=0 0011

AT Command

" Newline" for each Command (請注意：發送所有指令之前必須先停止掃描)

指令中 0001 代表設備的 ID Address，由此 ID 可設定指定設備的資料或指定該設備傳回資料，參數範圍從 0001~9999：

#	AT Command	RFID Reader Return
1	AT+0000-FindDeviceID	+0000-FindDeviceID:0001
2	AT+0001-DeviceID:0002	+0001-DeviceID:0002
3	AT+0001-Scan:0	+0001-Scan:0
4	AT+0001-VER	+WenShing RFIDBY4 Reader 1.00
5	AT+0001-BuzzTime:3	+0001-BuzzTime:3
6	AT+0001-BuzzONOFF:0	+0001-BuzzONOFF:0
7	AT+0001-Reset	+0001-Reset

8	AT+0001-SetPower:30dBm	
		+0001-SetPower:30dBm
9	AT+0001-Mode:S0	
		+0001-Mode:S0
10	AT+0001-SetQuery:SL=0,SS=0,TG=0,Q4	
		+0001-SetQuery:SL=0,SS=0,TG=0,Q4
11	AT+0001-ReadDeviceMessage	+0001-ReadDeviceMessage
		+Sel=0

		+Session=1
		+Qbegin=4
1	AT+0001-Read:1,02,00000000,06,201309248726030001020022	
2		
		+0001-Read:1,02,00000000,06,201309248726030001020022<00> →201309248726030001020022 或 +0001-Read:1,02,00000000,06,201309248726030001020022<09>

Wei

AT+0001-Write:3,00,00000000,201309248726030001020022,098765432109
87654321

1
3

AT+0001-Write:3,00,00000000,201309248726030001020022,0987654321098765
4321<00>

1. 執行“Wenshing All in one NET tools”，開啟後畫面如下：

Wenshing All in one NET tools

Parameters:

work mode: MOD-SERVER-RTU

Default Gateway: 192.168.001.001

Subnet mask: 255.255.255.000

Device IP: 192.168.001.002

Device port: 10006

Mac Address: 00-A5-89-C2-61-63

Destination IP: 192.168.001.003

Destination Port: 10006

Baud Rate(bps): 115200

Data/Parity/stop: 8 NONI 1

Delay Send(ms): 50 ms (毫秒)

ID: 01 connect data reset

Version: V42 Type: NNZN

Update All Online Device

Setup via COM

Factory Setting

Setup via NET

Factory Setting

Online Device

Device IP	Mac Address	Version	Type
-----------	-------------	---------	------

2. 搜尋區域網路內的設備，點選“Search in LAN”鍵：

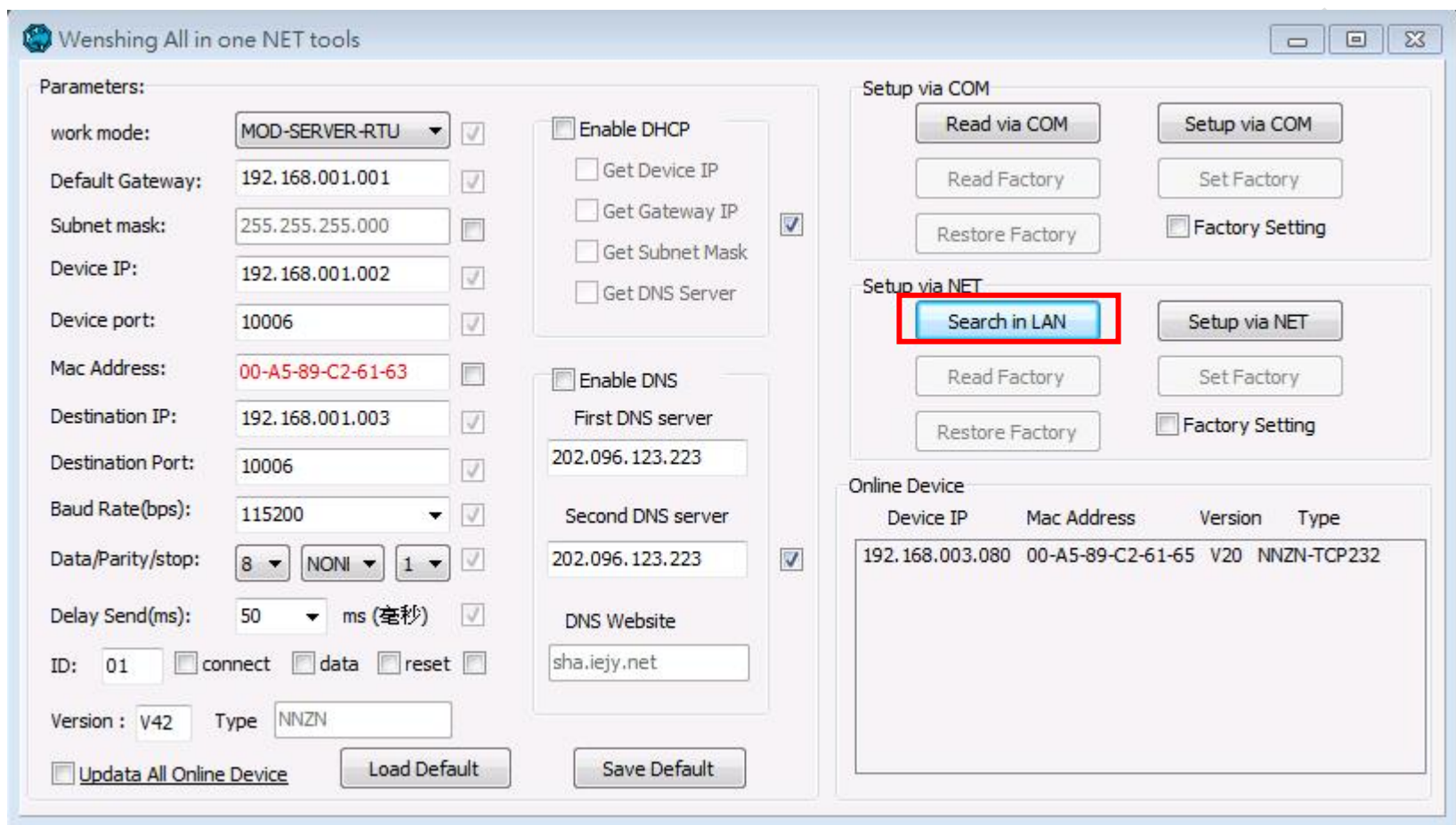

3. 搜尋到設備後會在下面顯示出該設備的 IP 位置：

Online Device			
Device IP	Mac Address	Version	Type
192.168.003.080	00-A5-89-C2-61-65	V20	NNZN-TCP232

4. 讀取網路設定參數，點擊兩次搜尋到的設備 IP 後會自動讀取目前的設定並在左邊“Parameters”顯示出來：

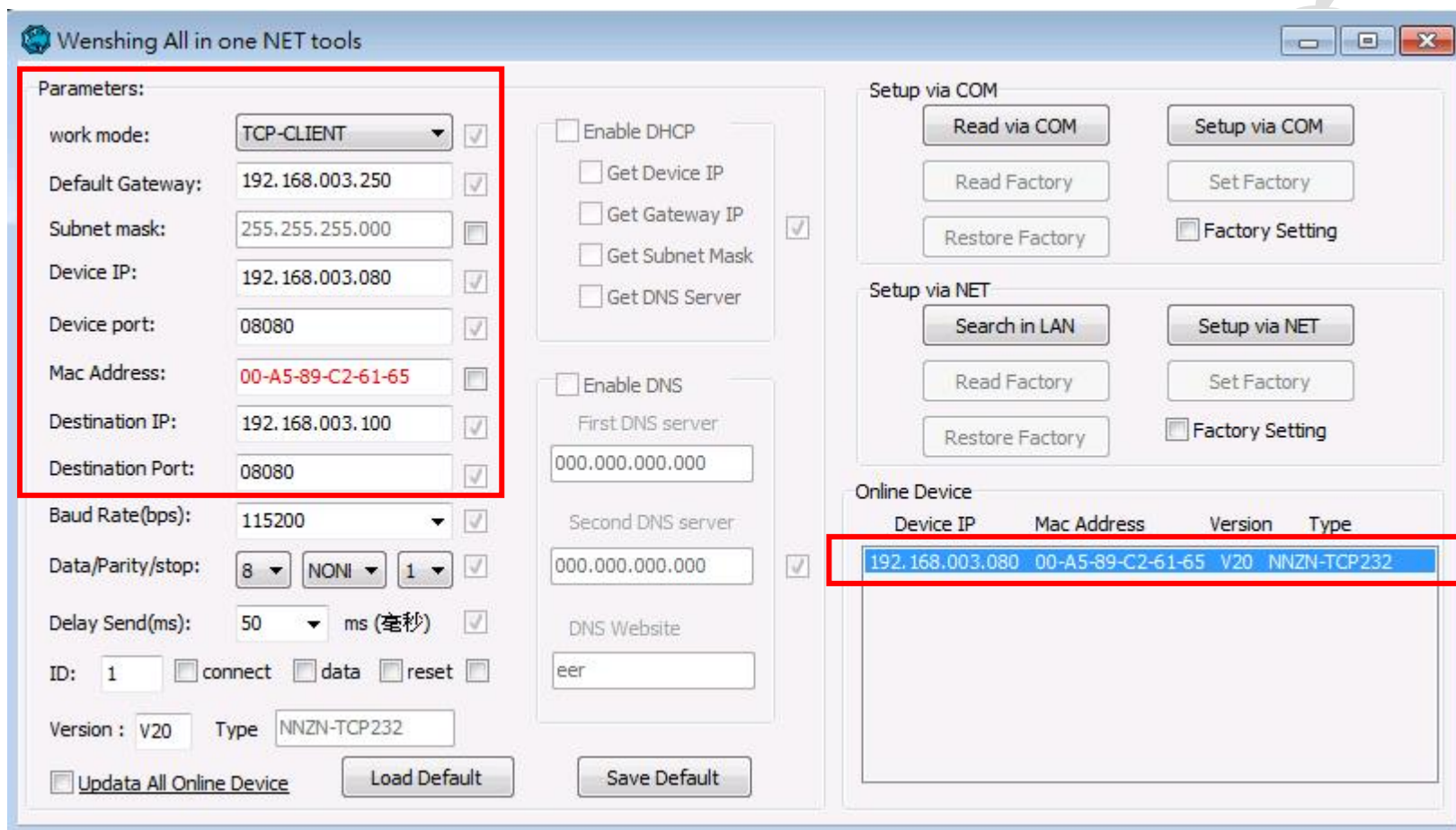

5. 修改更新主機的工作模式、IP 位置、Device port，並按“Setup via NET”鍵進行修改：

Wenshing All in one NET tools

Parameters:

work mode: UDP-CLIENT

Default Gateway: 192.168.003.250

Subnet mask: 255.255.255.000

Device IP: 192.168.003.080

Device port: 5978

Mac Address: 00-AC-FB-16-71-55

Destination IP: 60.251.71.55

Destination Port: 5978

Baud Rate(bps): 115200

Data/Parity/stop: 8 NONI 1

Delay Send(ms): 50 ms (毫秒)

ID: 1 connect data reset

Version: V22 Type NNZN-TCP232

Update All Online Device

Enable DHCP

Get Device IP

Get Gateway IP

Get Subnet Mask

Get DNS Server

Enable DNS

First DNS server: 000.000.000.000

Second DNS server: 000.000.000.000

DNS Website: eer

Setup via COM

Factory Setting

Setup via NET

Factory Setting

Online Device

Device IP	Mac Address	Version	Type
192.168.003.080	00-AC-FB-16-71-55	V22	NNZN-TCP232

6. 修改成功則會跳出下列提示：

All in one net tools

192.168.3.80 Set up complete and automatic restart

7. 重新啟動，將 WS-RFIDBY 設備拔除電源再重新插上，開始更新時燈號由綠紅藍反覆交替變換並有聲音提示，更新成功後會重新啟動並進入待機模式。
8. 使用 “Wenshing All in ont NET tools” 修改適合的網路設定，參考 PC 有線網路設定方式。

表 1 : Read/Write Error code

#	Type	Code	Description
1	Command Error	0x17	命令幀中指令代碼錯誤
2	FHSS Fail	0x20	跳頻搜索頻道超時。所有頻道在這段時間內都被佔用
3	Inventory Fail	0x15	輪詢操作失敗。沒有標籤返回或者返回資料 CRC 校驗錯誤
4	Access Fail	0x16	Access 標籤失敗，有可能是 Access password 不對
5	Read Fail	0x09	讀標籤數據存數區失敗。標籤沒有返回或者返回資料 CRC 校驗錯誤
6	Read Error	0xA0 Error code	讀標籤資料存儲區錯誤。返回的代碼由0xA0及表3 Error Code得到。Error code信息詳見下表
7	Write Fail	0x10	寫標籤數據存數區失敗。標籤沒有返回或者返回資料CRC 校驗錯誤
8	Write Error	0xB0 Error code	寫標籤資料存儲區錯誤。返回的代碼由0xB0及表3 Error Code得到。Error code信息詳見下表
9	Lock Fail	0x13	鎖定標籤資料存數區失敗。標籤沒有返回或者返回資料CRC 校驗錯誤
10	Lock Error	0xC0 Error code	鎖定標籤資料存儲區錯誤。返回的代碼由0xC0及表3 Error Code得到。Error code信息詳見下表
11	Kill Fail	0x12	Kill 標籤失敗。標籤沒有返回或者返回資料 CRC 校驗錯誤
12	Kill Error	0xD0 Error code	Kill標籤錯誤。返回的代碼由0xC0及表3 Error Code得到。Errorcode信息詳見下表

例如錯誤代碼回傳<B3> 代表是表 1 第 8 項及表 3 第 2 項，Write Error 寫標籤資料存儲區錯誤，指定的標籤資料存儲區不存在；或者該標籤不支援指定長度的 EPC，比如 XPC

表 2 : NXP G2X 標籤特有指令錯誤代碼

#	Type	Code	Description
1	ReadProtect Fail	0x2A	ReadProtect指令失敗，標籤沒有返回資料或者返回資料CRC校驗錯誤
2	Reset ReadProtect Fail	0x2B	Reset ReadProtect指令失敗，標籤沒有返回資料或者返回資料CRC校驗錯誤
3	Change EAS Fail	0x1B	Change EAS指令失敗，標籤沒有返回資料或者返回資料CRC校驗錯誤
4	NXP 特有指令標籤返回的錯誤代碼	0xE0 Error code	NXP特有指令標籤返回的錯誤代碼，錯誤代碼由0xE0及表3 Error Code得到

表 3 : EPC Gen2 協定中標籤返回錯誤代碼

#	Type	Code	Description
1	Error-specific	0	其他所有錯誤
2		3	指定的標籤資料存儲區不存在；或者該標籤不支援指定長度的EPC，比如XPC
3		4	指定的標籤資料存儲區被鎖定並且/或者是永久鎖定，而且鎖定狀態為不可寫或不可讀
4		B	標籤沒有收到足夠的能量來進行寫操作
5	Non-specific	F	標籤不支持 Error-code 返回